

PARTS LIST			
ITEM	QTY	PART NO.	PART DESCRIPTION
1	1	SCX3	3/8" x 8" x 9-1/4" CROSSOVER PLATE
2	4	GUB-4355	1/2" x 3-5/8" x 5" GALV U-BOLT KIT

**U-BOLT KIT INCLUDES:**  
 (1) GALVANIZED U-BOLT  
 (2) GALVANIZED LOCK WASHERS  
 (2) GALVANIZED FLAT WASHERS  
 (2) GALVANIZED NUTS

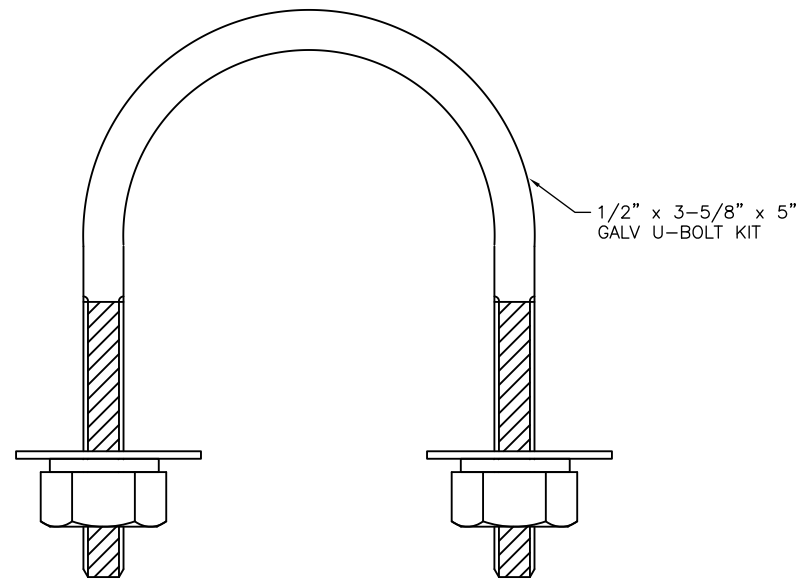
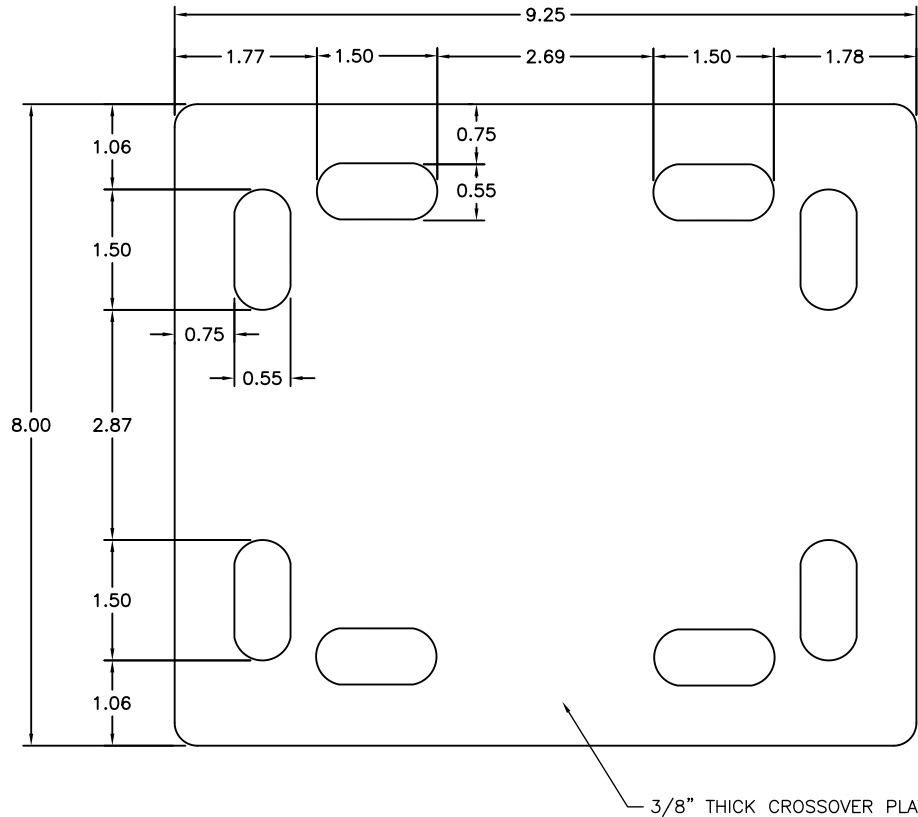

**FINISH:**  
HOT DIP GALVANIZED

**WEIGHT:**  
11.0LBS.

**TOLERANCE UNITS**

TOLERANCES ON DIMENSIONS, UNLESS OTHERWISE NOTED ARE:  
 SAWED, SHEARED AND GAS CUT EDGES ( $\pm .030$ "")  
 DRILLED AND GAS CUT HOLES ( $\pm .030$ "")—NO CONING OF HOLES  
 LASER CUT EDGES AND HOLES ( $\pm .010$ "")  
 BENDS ARE  $\pm 1/2$  DEGREE  
 ALL OTHER MACHINING ( $\pm .030$ "")  
 ALL OTHER ASSEMBLY ( $\pm .060$ "")

**PROPRIETARY NOTE:**

THE DATA AND TECHNIQUES CONTAINED IN THIS DRAWING ARE PROPRIETARY INFORMATION OF IZZY INDUSTRIES AND CONSIDERED TRADE SECRET. ANY USE OR DISCLOSURE WITHOUT THE CONSENT IF IZZY INDUSTRIES IS STRICTLY PROHIBITED.

PART NO.		CP-3030	
DESCRIPTION			
CROSSOVER PLATE 3-1/2" O.D. TO 3-1/2" O.D.			
DRAWN BY:	 701 Riverwood Drive Pembroke, NH 03275	REVISION:	
NMB		1	
CHECKED BY:		SCALE:	
DATE:		SHEET:	
09.21.17		1 OF 1	