

PC-30-10
 Pipe-to-Pipe Clamp, heavy duty, joins two 1-1/2 in to 3-1/2 in OD round members

PARTS LIST				
ITEM	QTY	PART NO.	PART DESCRIPTION	WEIGHT
1	8	CLAMP	1/2" x 1-1/2" x 6-1/4" BENT METAL CLAMP	-
2	4	THREADED ROD	1/2" x 10" THREADED ROD	-

PIPE TO PIPE CLAMP SET INCLUDES:
 (8) GALVANIZED BENT METAL CLAMPS
 (4) GALVANIZED THREADED ROD
 (16) GALVANIZED NUTS
 (16) GALVANIZED LOCK WASHERS
 (16) GALVANIZED FLAT WASHERS

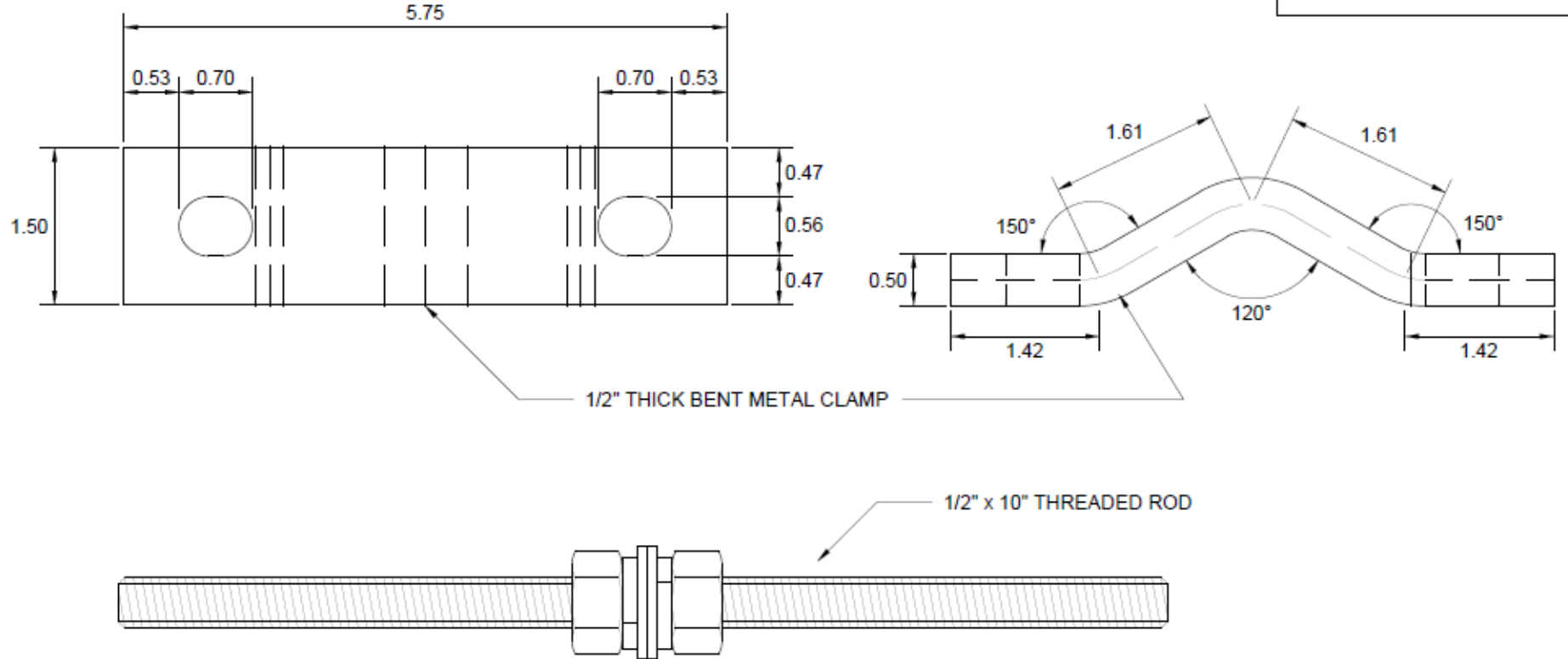

FINISH:
 HOT DIP GALVANIZED

Weight: 13lbs

TOLERANCE UNITS
 TOLERANCES ON DIMENSIONS, UNLESS OTHERWISE NOTED ARE:
 SAWED, SHEARED AND GAS CUT EDGES ($\pm .030$ ")
 DRILLED AND GAS CUT HOLES ($\pm .030$ ") - NO CONING OF HOLES
 LASER CUT EDGES AND HOLES ($\pm .010$ ")
 BENDS ARE $\pm 1/2$ DEGREE
 ALL OTHER MACHINING ($\pm .030$ ")
 ALL OTHER ASSEMBLY ($\pm .060$ ")

PROPRIETARY NOTE:
 THE DATA AND TECHNIQUES LOCATED IN THIS DRAWING ARE PROPRIETARY INFORMATION OF IZZY INDUSTRIES AND CONSIDERED SECRET. ANY USE OR DISCLOSURE WITHOUT THE CONSENT OF IZZY INDUSTRIES IS STRICTLY PROHIBITED.

PART NO.		PC-30-10	
DESCRIPTION		PIPE TO PIPE CLAMP	
DRAWN BY:	 <p>701 Riverwood Drive Pembroke, NH 03275 925.344.5970</p>	REVISION:	-
CHECKED BY:		SCALE:	-
DATE:		SHEET:	1 OF 1